

LOC	DIST	REVISIONS			
P	LTR	DESCRIPTION	DATE	DWN	APVD
	O	REL. PER NPR98-3	4-22-98	LM	PS
	A	REV PER EC 0G3C-95-99	22SEP99	DH	MZ

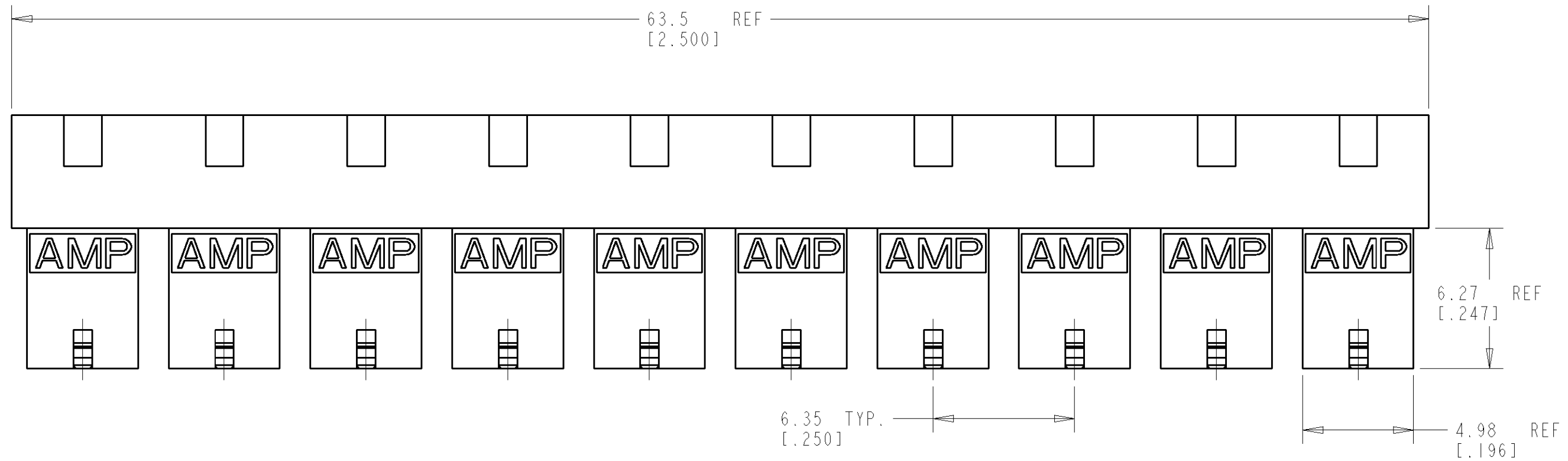

- MATERIAL:
HOUSING: GLASS-FILLED POLYESTER
CONTACT: PHOSPHOR BRONZE
 - CONNECTOR MATES WITH 0.64 [0.025] SQUARE POSTS.
 - PART DENOTES INDIVIDUAL TWO POSITION SHUNT WHICH IS PACKAGED ON BREAKAWAY COMBS OF TEN SHUNTS.
- ④ ASSEMBLIES ARE DELIVERED IN STICKS OF TEN PARTS.
 - ⑤ FINISH: 1.27µm [0.000050] MIN NICKEL UNDERPLATE OVERALL.
 - ⑥ FINISH: 0.76µm [0.000030] MIN GOLD IN CONTACT AREA.
 - ⑦ FINISH: 0.38µm [0.000015] MIN GOLD IN CONTACT AREA.

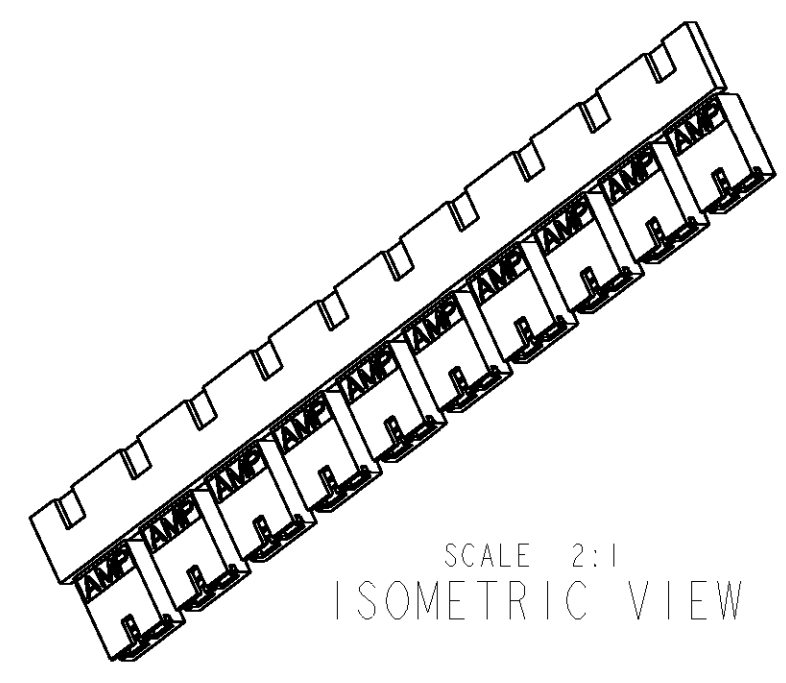
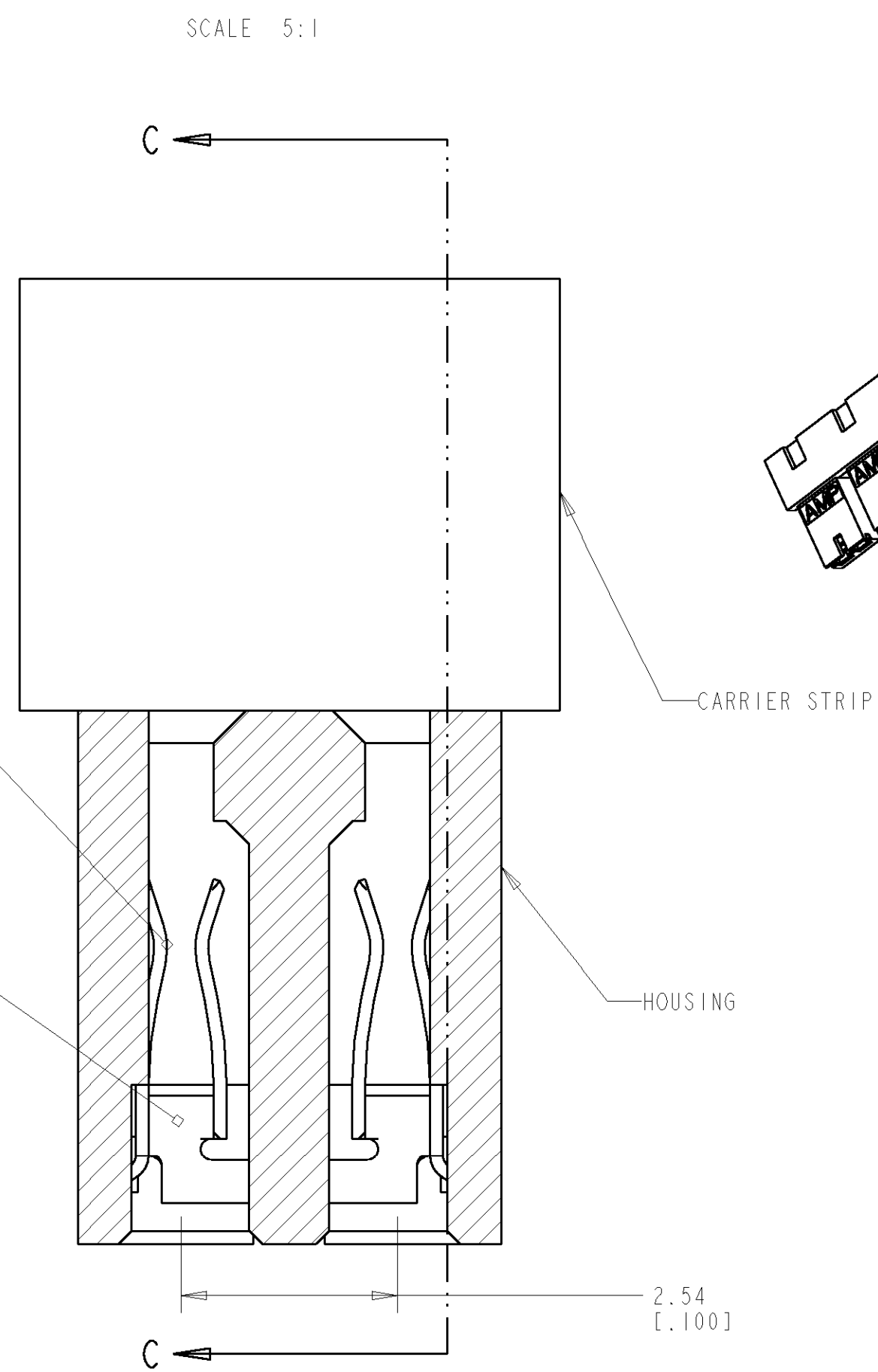
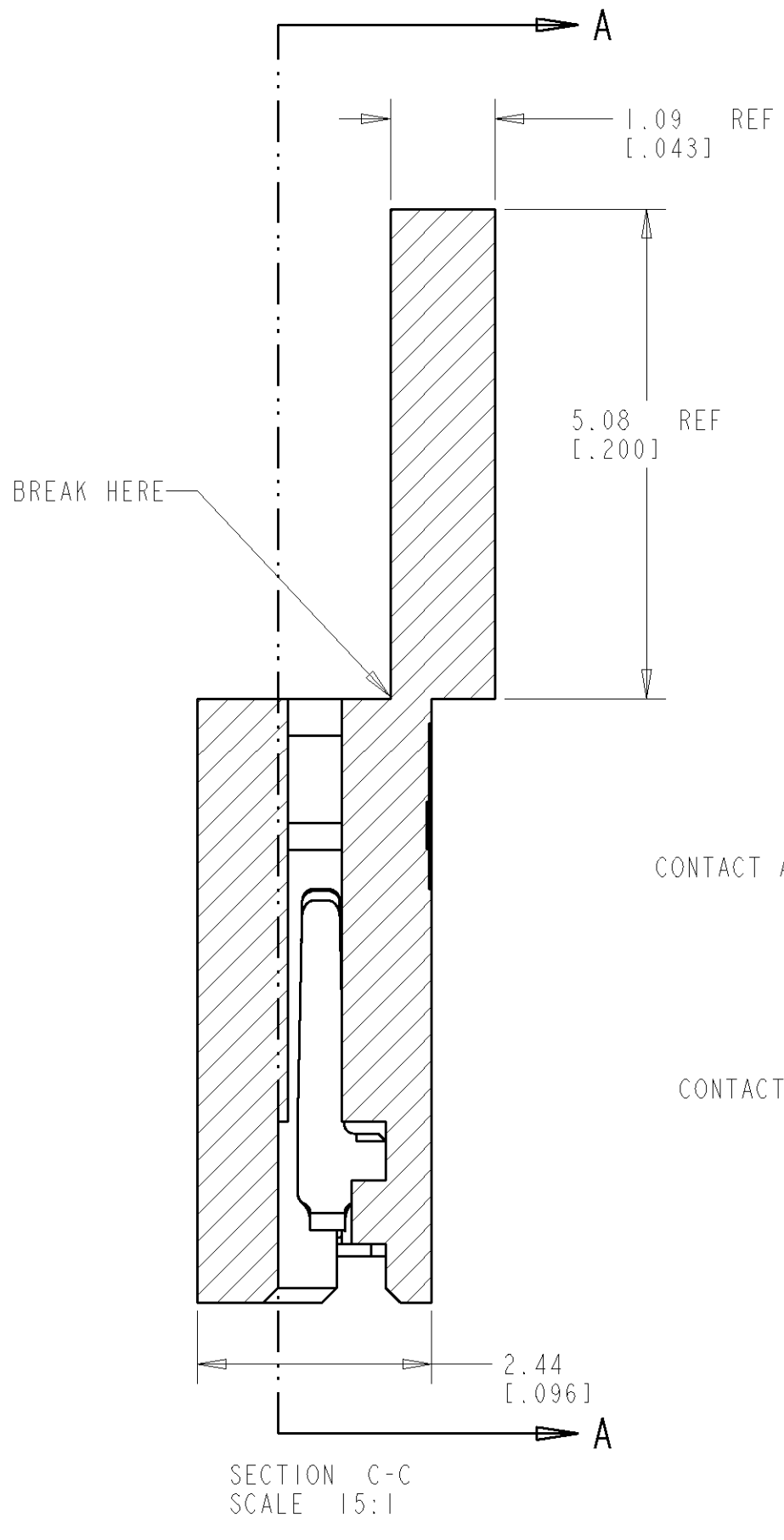

YELLOW	30AU	390088-5	④ ⑤ ⑥
BLUE	15AU	390088-4	④ ⑤ ⑦
BLUE	30AU	390088-3	④ ⑤ ⑥
BLACK	15AU	390088-2	④ ⑤ ⑦
BLACK	30AU	390088-1	④ ⑤ ⑥
HOUSING COLOR	GOLD PLATING	PART NUMBER	NOTES

THIS DRAWING IS A CONTROLLED DOCUMENT FOR AMP INCORPORATED. IT IS SUBJECT TO CHANGE AND THE CONTROLLING ENGINEERING ORGANIZATION SHOULD BE CONTACTED FOR THE LATEST REVISION.		DWN 22-Sep-99 CHK D.WIEBKING DGH 14-NOV-97 APVD PPS 14-NOV-97	AMP Incorporated Harrisburg, PA 17105-3608
DIMENSIONS: MM [INCH]	TOLERANCES UNLESS OTHERWISE SPECIFIED: 0 PLC ± 1 PLC ± 2 PLC ± 3 PLC ±.003 4 PLC ± ANGLES ±	PRODUCT SPEC - APPLICATION SPEC - WEIGHT - CUSTOMER DRAWING	NAME SHUNT, DUAL BEAM .100 CL SIZE A2 CAGE CODE 00779 DRAWING NO. 390088
MATERIAL - SEE NOTE 1	FINISH - SEE NOTE 3	SCALE SHT.	SHEET 1 OF 1 REV A